

Three-phase flat motor
 n1=2,800 1/min
 220-240/380-415V - 50Hz
 Direction of rotation RIGHT
 (designed for frequency
 inverter operation, adjustable up to 100Hz)

View A-A

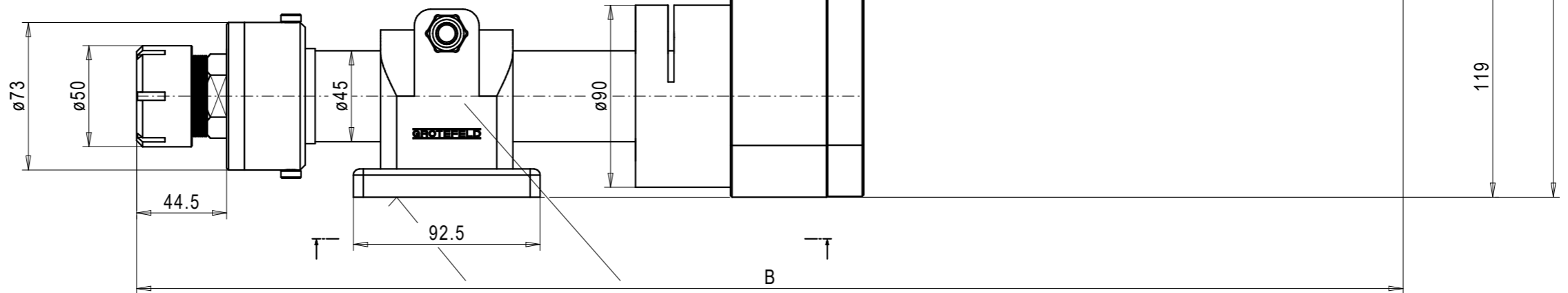
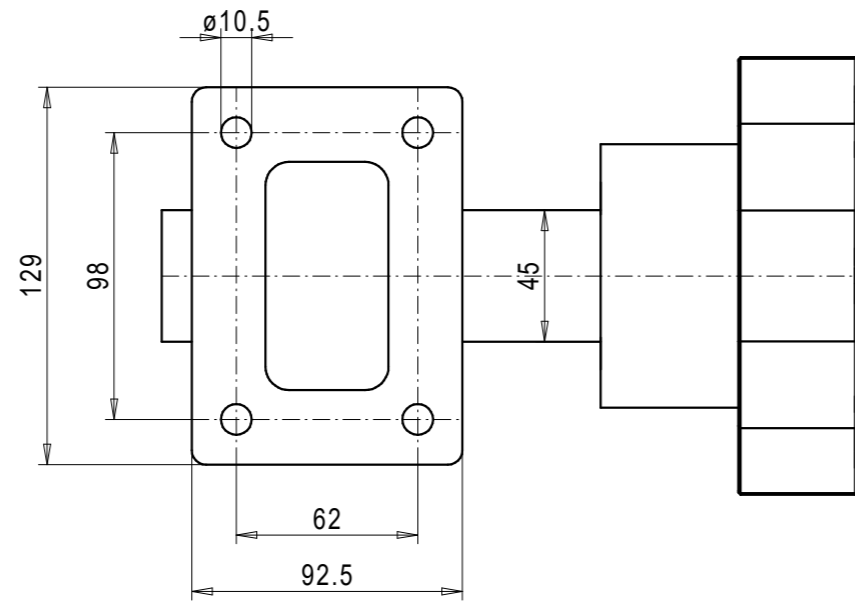
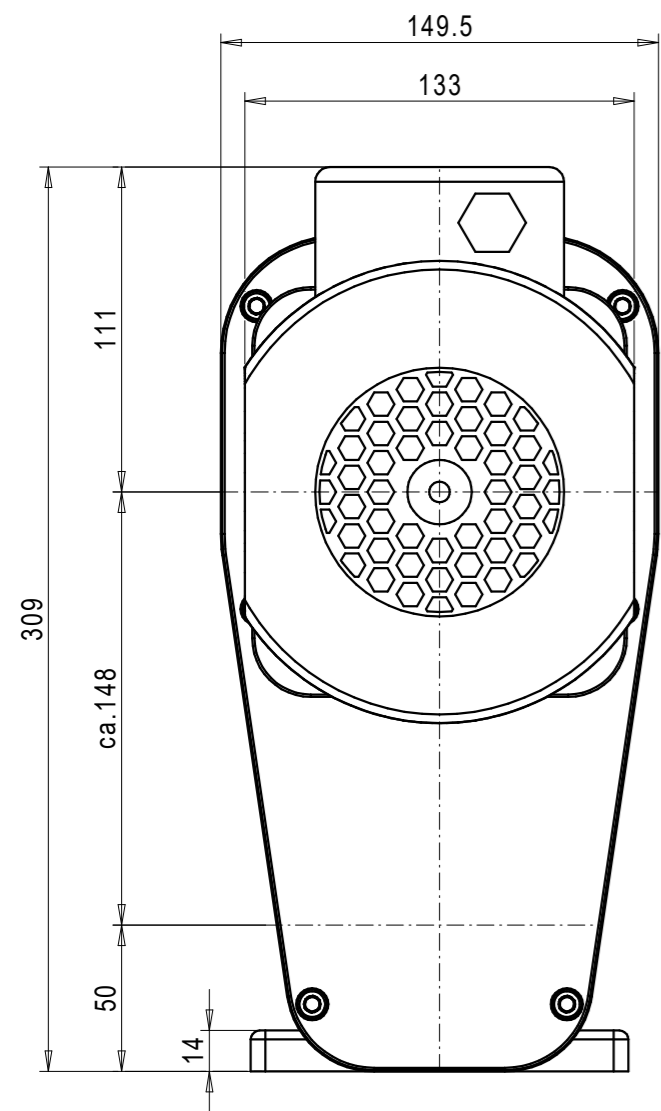

Mounting Surface

Flange clamp FK45
 rotatable, movable

Collet chuck HI-Q/ER32

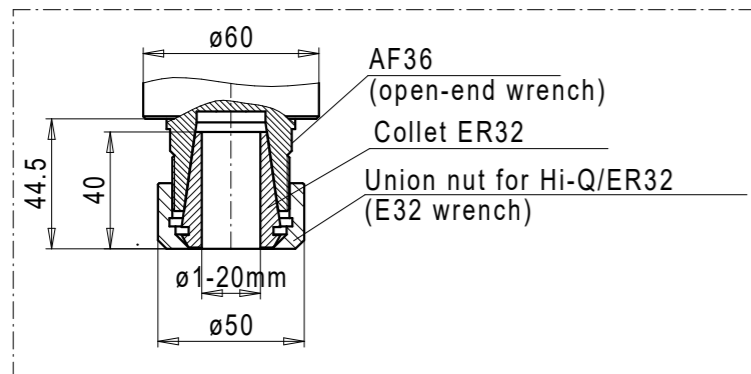

	1,7kW	2,2kW
A	267	284
B	627	644